



Fred Hartman Bridge over Houston Ship Channel Baytown/Laport, Texas

Is the look of a bridge rail design of concern to you as an engineer?

Though railing constitutes only 2 to 5 percent of the total cost of a bridge, it is of immense value to the citizens that will use that bridge every day. No matter how magnificent the total bridge design, the visual appeal of the railing affects public acceptance. As a result an increasing number of bridge engineers across the nation choose **elliptical bridge rail**.

Product

Tex-Tube Elliptical Bridge Rail

Specifications

API 5L GRADE X52 PSL2 TYPE E
4-7/8" x 8" x .188" (various lengths)
12.94 lbs./ft
Radii to 16'

Some Current Rail Types

TxDOT HT Rail (TL5)
TXDOT T401 & C402 Rail (TL3)
PennDOT HT Rail (TL5)
FDOT Special Rail (TL4)

Contact

GSI Highway Products
gshighway.com
(972) 225-1660

john@gshighway.com

The elliptical railing has been used on highway bridges for over 50 years, and it's still the **right choice**. Texas, Pennsylvania, Florida, and Maryland among other states currently use elliptical tube in NCHRP 350 Test Level 3 (TL3) and Test Level 5 (TL5) bridge rail applications, and in MASH evaluation. Florida DOT has used it to retrofit many of the older concrete bridges throughout the state.

It can be seen on signature projects like the Fred Hartman Bridge over the Houston Ship Channel in Texas, the Woodrow Wilson Bridge outside of Washington D.C., and the **Santiago Calatrava Bridge** on IH30 over the Trinity River in Dallas, Texas. It will soon be seen on the Harbor Bridge Project in Corpus Christi, Texas (Flatiron/ Dragados, LLC) and the Ship Channel Bridge (HCTRA) in Houston.

The elliptical railing is one of those **most used** by TxDOT. The reason is simple - among its many advantages, it provides an open and eye-pleasing design!

And it is **crashworthy**. The elliptical shape¹ provides increased resistance to bending in the long axis, offering the strength of 6-inch pipe with the appearance of four. Field experience in Texas has shown the

elliptical rail performing ideally under tremendous impact. A mill-rolled mating splice tube is available as well, with a **superior** fit that has held up in crashes beyond DOT expectations.²

The lack of consistency in the "squashed" shape has hindered DOT adoption of elliptical rail in the past, but what GSI offers is mill-rolled elliptical tube that provides superior **consistency** in shape and splice tube fit, **ElliptiSafe™**.

GSI is the master distributor for mill-rolled elliptical tube produced by the **TEX-TUBE** of Houston. **TEX-TUBE's** elliptical shape is continuously produced off the mill to the API 5LX (52) specification thus having a higher strength-to-weight ratio than standard round pipe. This strength-to-weight ratio produces an elliptical pipe weighing 12.94 pounds per foot compared to 18.97 pounds per foot of a "squashed" standard schedule 40 round pipe. This allows for **reduced material costs** and easier field handling, thus stretching valuable tax dollars.

GSI's ElliptiSafe™ is the best answer to your state's bridge rail needs.

1. Dr. Dean Alberson, former Assistant Director, TTI
2. Mark Bloschok, former Bridge Engineer, TxDOT

Elliptisafe™ Bridge Rail State Standards

TxDOT T402 Traffic Rail 42" tall (TL-3)

Northshore Park, The Woodlands, Texas

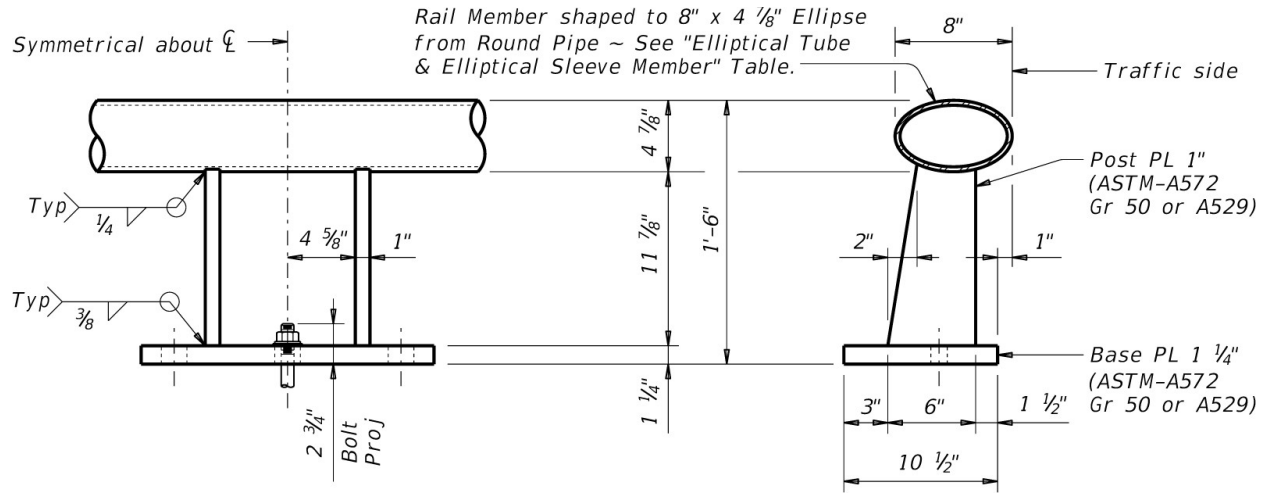

TxDOT C402 Combination Traffic and Pedestrian Rail

Plantation Reserve Golf Course, Florida

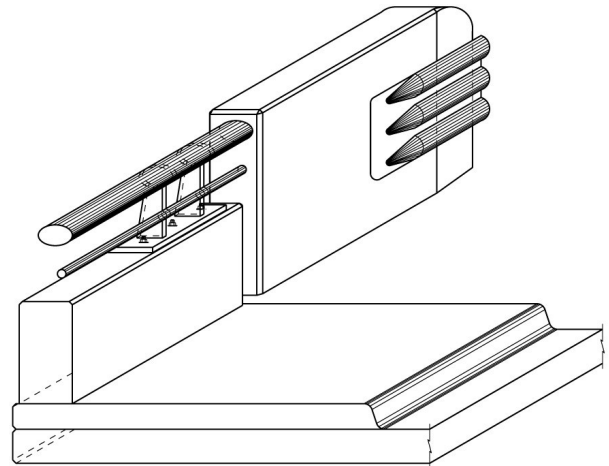
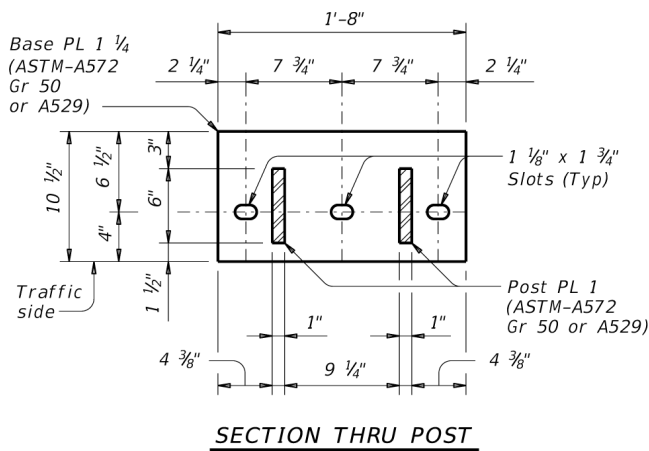

TxDOT T80HT Heavy Truck Traffic Rail

Beltway 8, Houston, Texas

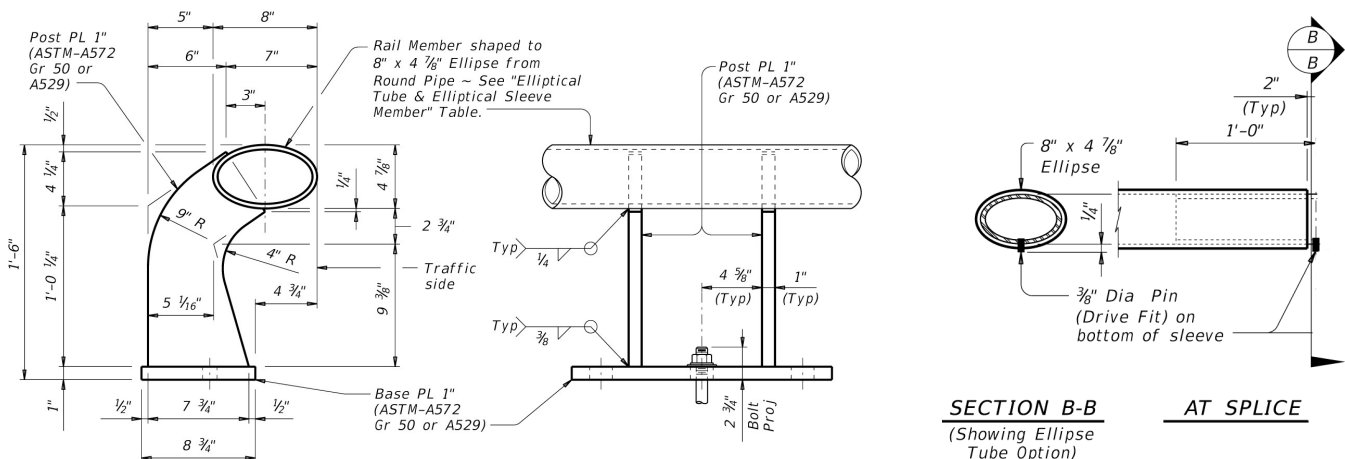

Problem: Retrofit Obsolete Concrete Bridge Railing

Solution: FDOT Elliptical Bridge Rail (TL4)

Project: Six bridges in FDOT District 4

An FDOT District Engineer tasked with bringing obsolete bridge railing up to current TL-4 standards contacted FDOT Senior Structures Design Engineer, Charles E. Boyd, P.E., to discuss available options. He already knew he could replace the safety shape or parapet type railing with a new F-Shape railing, or that he could replace the parapet type railing with a vertical face or three-beam retrofit. Effective options, but costly and time consuming.

Then Mr. Boyd had an idea. Due to the extensive use of elliptical bridge rails throughout Texas, Mr. Boyd contacted Mark Bloschock, a TxDOT Bridge Engineer, to discuss whether the TxDOT elliptical bridge railing could be used to retrofit his obsolete FDOT bridge. Mr. Bloschock had the perfect solution.

The Texas Transportation Institute (TTI) had worked with TxDOT to develop their current elliptical bridge railing standards. Mr. Boyd asked TTI to utilize the standard TxDOT T402 (TL3) and develop a TL4 elliptical railing to retrofit four obsolete concrete bridge railing designs in Florida.

The result was ElliptiSafe™, which replaced the previous railings on all four bridges to bring those structures up to the required FDOT TL-4 standard. The first project to use this standard, pictured on this page, dates from 2007. This rail design has saved the state valuable revenue compared to the other options available.

Retrofitting bridges is simple and easy. For safety shape and parapet type rails with existing metal rail on top, the existing metal rail is removed and ElliptiSafe™ installed in its place, secured by new adhesive bonded anchor bolts. For safety shape railing lacking existing metal rail on top, ElliptiSafe™ is installed on top with the anchor bolts. Existing approach guardrail transitions typically need replacing or retrofitting for safety.

ElliptiSafe™ provides immediate savings and safety benefits. In contrast to standard three-beam or vertical face retrofit options, ElliptiSafe™ does not require any concrete demolition or reconstruction. This in turn reduces traffic control times, protecting state inspectors, construction workers, and the public from potential injury. Among all of ElliptiSafe's™ many benefits, this is the best.

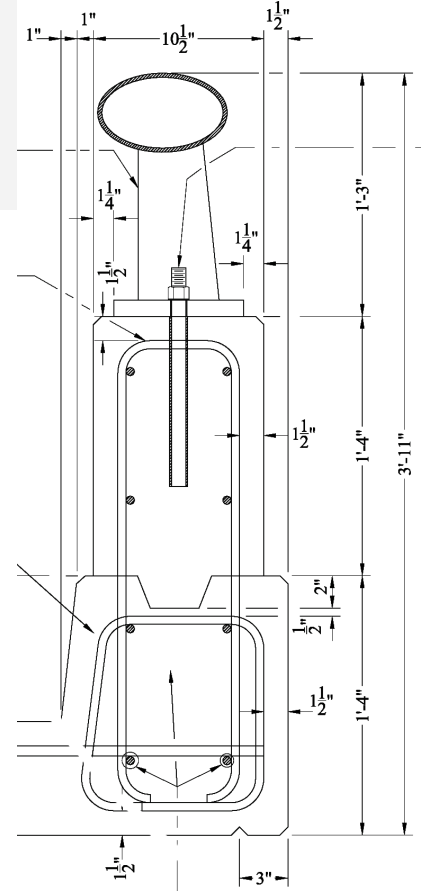

FDOT Elliptical Bridge Rail (TL4)

Developed by TTI for FDOT from TxDOT T402 Standard

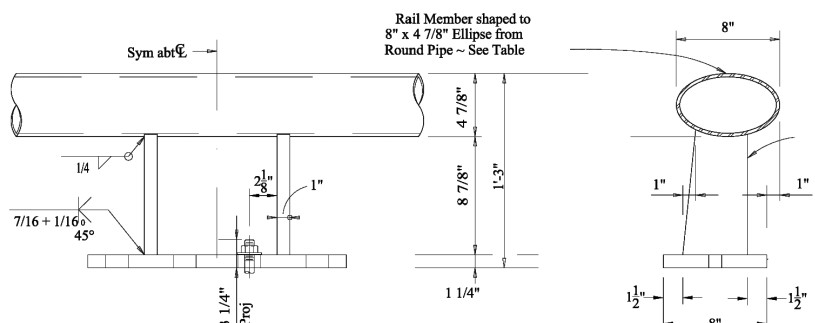
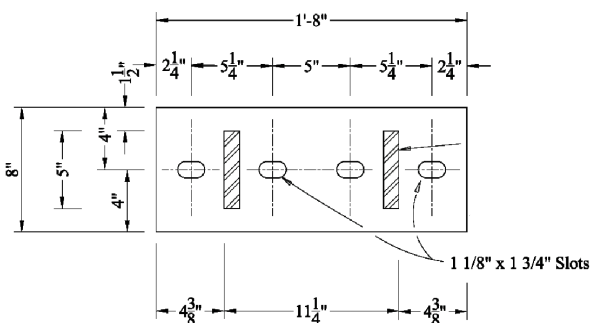

TEX-TUBE Elliptical Tube for Bridge Rail - Electrical Resistance Welded Pipe (ERW)

TEX-TUBE bridge rail is produced in continuous hot rolled lengths from the tube mill in an elliptical shape in accordance with the chemical, mechanical, and testing requirements of **API 5L GRADE X52 PSL2 TYPE E**.

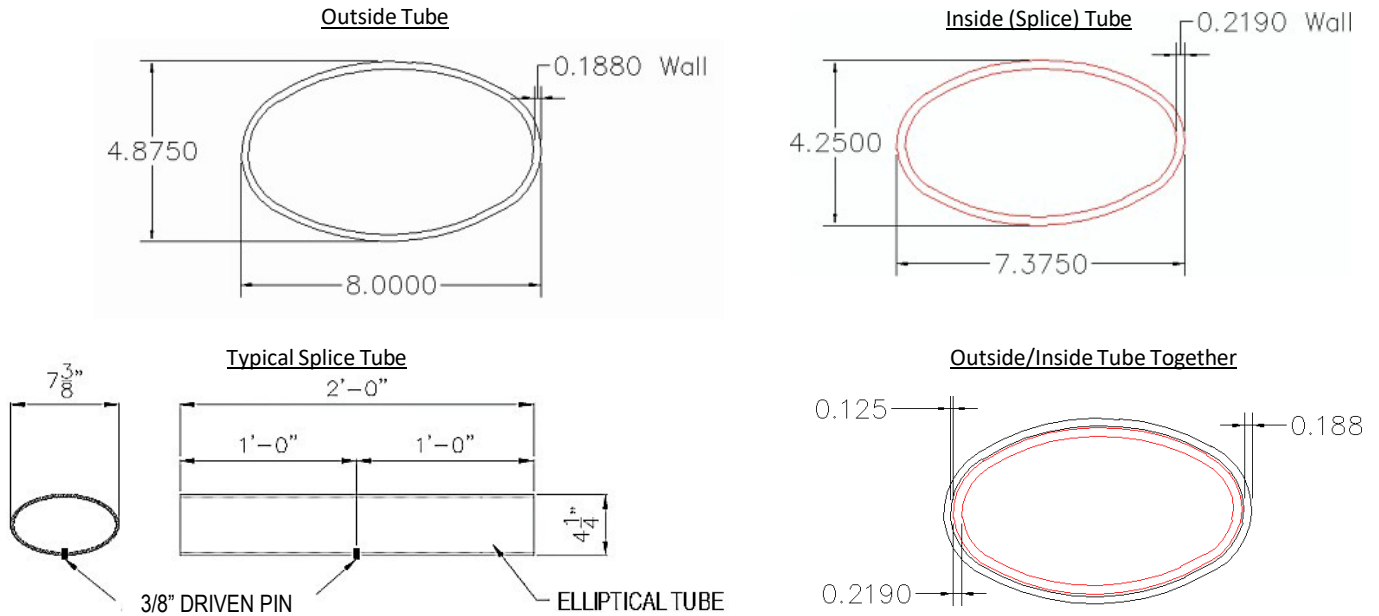

Specifications

- API 5L GRADE X52 PSL2 TYPE E welded pipe, except continuous
- Tube: 12.94 lbs./ft
- Splice: 13.6 lbs./ft
- 52,000 psi min yield strength
- 66,000 psi min tensile strength

Chemical Composition, max %

C	Mn	P	S	Ti
.22	1.40	.025	.015	.04

Dimensions

- Rail Tube: 4-7/8" x 8" x .188"
- Splice: 4-1/4" x 7-3/8" x 2' x .219"
- Stocked in lengths 30' to 50'
- Custom lengths available
- 10 pieces per bundle
- Minimum radius: 16'

Tube Fabrication Details

Elliptical Tube & Elliptical Sleeve Member		
8" x 4-7/8" Ellipse	Elliptical Sleeve Member	
Material	Material	Thickness
6" Dia Std Pipe ASTM-A53 E or S Gr B	ASTM-A53 Gr B	0.353"
	A36 or A500 Gr B	0.339"
GSI: 6-5/8" O.D. Pipe x 0.188"	API-5LX52	0.224"
	ASTM-A53 Gr B	0.339"
	A36 or A500 Gr B	0.325"
API-5LX52	API-5LX52	0.219"

GSI (outlined in orange) uses a schedule, thickness, and smaller diameter that allows for the least amount of weight.

Elliptisafe™ Bridge Rail



HT Rail (TL5) Susquehanna River Bridge
Harrisburg, Pennsylvania



TxDOT C4 Galvanized
Brushy Creek, Cedar Park, Austin, Texas



FDOT T401 (TxDOT Standard)
SH 94, Miami, Florida



TH80 (TL5) on I-95 over Potomac River
Woodrow Wilson Memorial Bridge, Maryland



TxDOT C402 Painted TL-3
Lake Lewisville Bridge, Lewisville, Texas



TxDOT T77 TL-3
TTI Test Center, Texas A&M University

Elliptisafe™ Bridge Rail



TxDOT HT TL-5, Designed by Santiago Calatrava
Margaret Hunt Hill Bridge, Dallas, Texas



TxDOT T4(S) Mod Painted
Arapaho Road Bridge, Addison, Texas



TxDOT T4 TL-3
Fred Hartman Bridge, Baytown, Texas



TxDOT T4 Painted TL-3 (42" tall)
SH 620 at US 183, Austin, Texas



FDOT C402 Painted (TxDOT Standard)
Preserve Golf Course, Plantation, Florida

For more information & pricing

GSI Highway Products
Gsihighway.com
(972) 225-1660
john@gsihighway.com



What we build here, SAVES LIVES!