

Typical Rail Detail

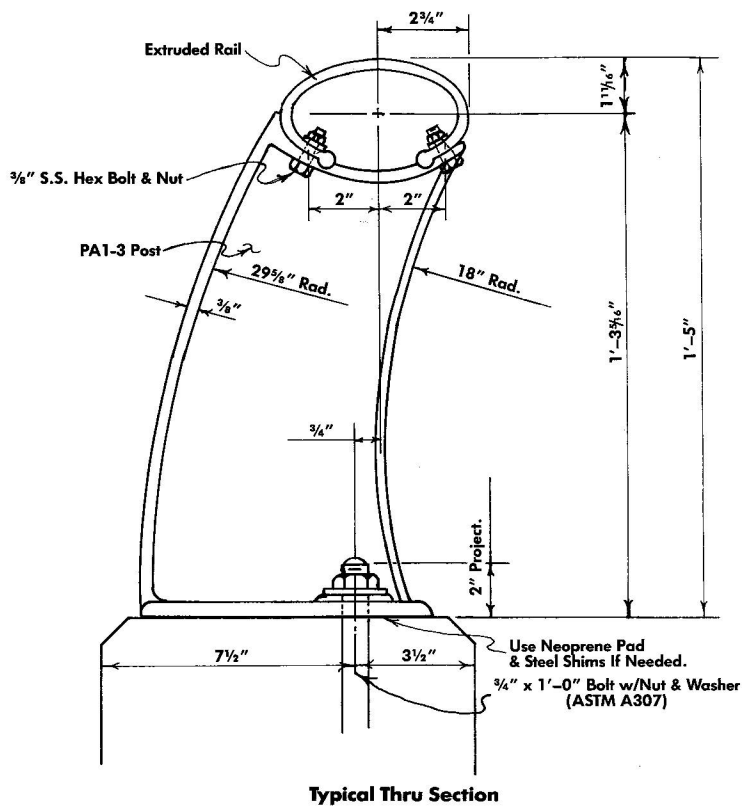

Typical Thru Section

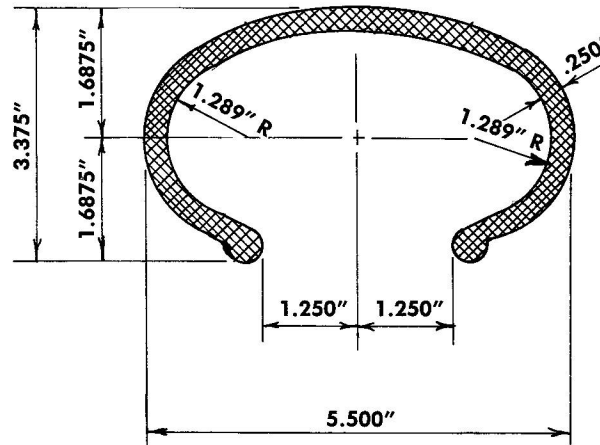

**Rail Member
Die #11136-B**

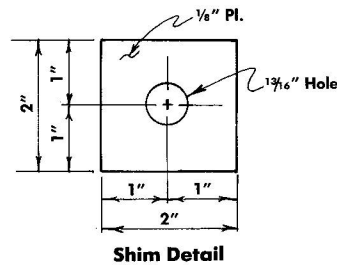

Shim Detail

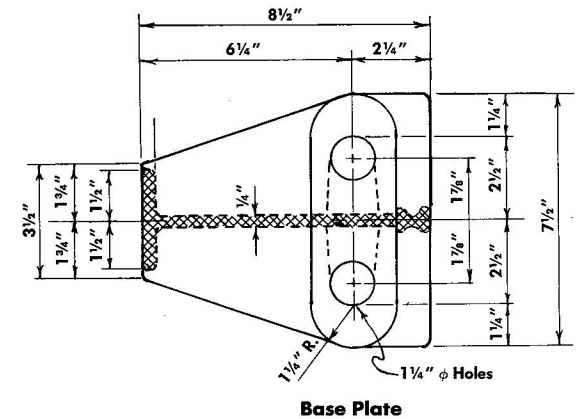

Base Plate

**Aluminum Pedestrian Rail
PA1-3**

GENERAL NOTES:

- Posts Shall Be Aluminum Alloy A-356.
- Rail Is Extruded Aluminum Alloy 6061-T6.
- Anchor Bolts To Be Galvanized.
- Post Sits on Neoprene Pad.
- Rail Mounting Screws To Be Stainless Steel.
- Conforms To Texas State Std. For Type A Rail.

**Gordon's Specialties Inc.
Dallas, Texas**